

SPECIFICATION SHEET

Hitch Mount Vehicle Counterweight Davit Base



30076S:

Hitch mount Vehicle base Counterweight base c/w bag & steel stillage

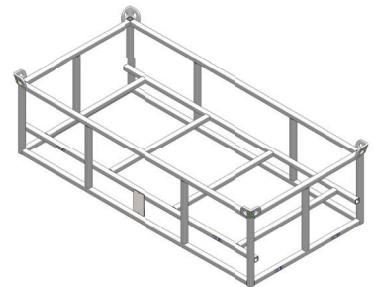

Davit base Footprint

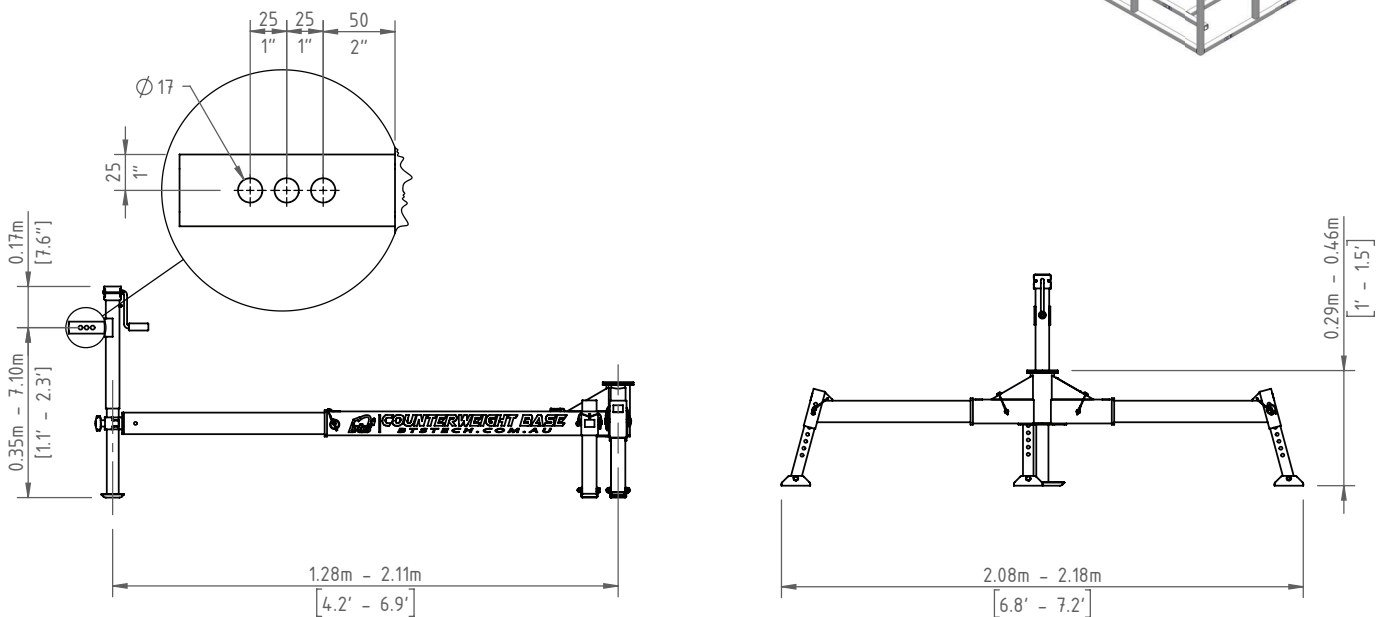

Weight: Total 56kg (123lbs)

Separates into easy to carry components: Base weight 12kg (26lbs), Outrigger legs 5kg (11lbs) each, Stabilizer jack 5kg (11lbs), Heavy Duty storage bag 4kg (9lbs). Steel Stillage frame 25kg (55lbs)

Material specifications:

- Aluminium (Anodized / Powder coated)
- Steel (Galvanized / Painted)

Shipping dimensions:

Length: 1.49m (59") – **Width:** 0.74m (29") – **Height:** 0.43m (17")

Weight: 56kg (123lbs)

Also available with stacking stillage for multiple units.



SPECIFICATION SHEET

Vehicle Hitch Mount / Counterweight Davit Base



Set-up options

Hitch Mount

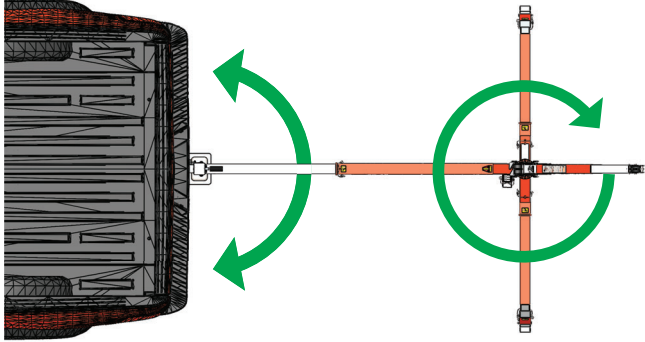

Rotation option of base (up to 90°) and 360° rotation of davit

Counterweight

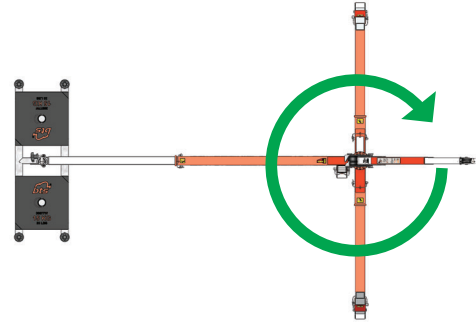

360° rotation of davit

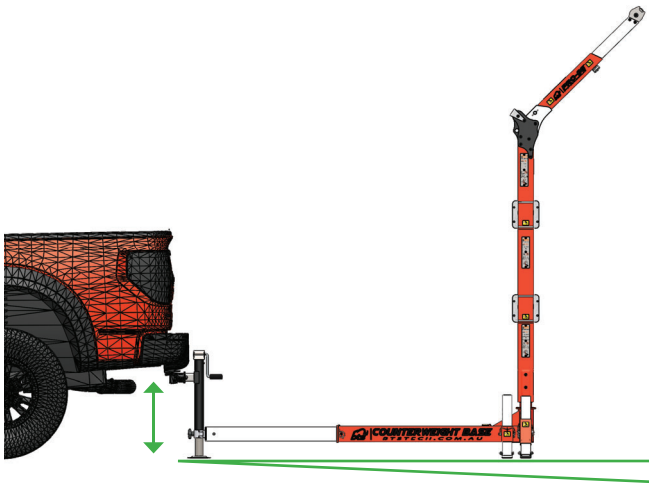

Hitch height options (340-710mm / 13"-28")
ground fall Max 4° (165mm / 6.5")

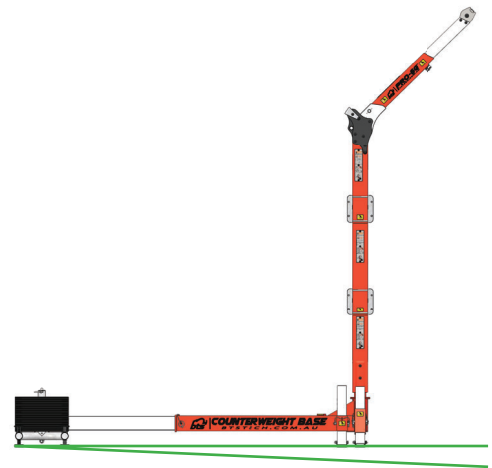

Ground fall Max 4° (165mm / 6.5")

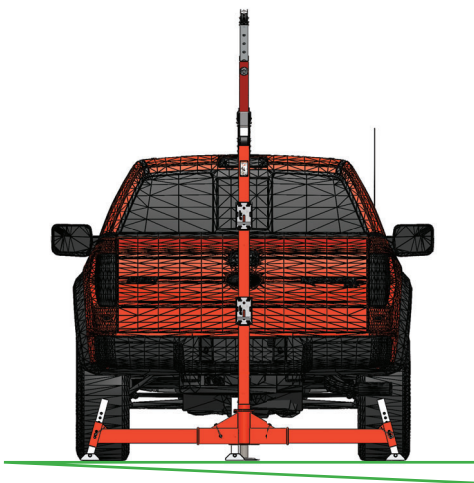

Ground fall Max 5° (170mm / 6.8")

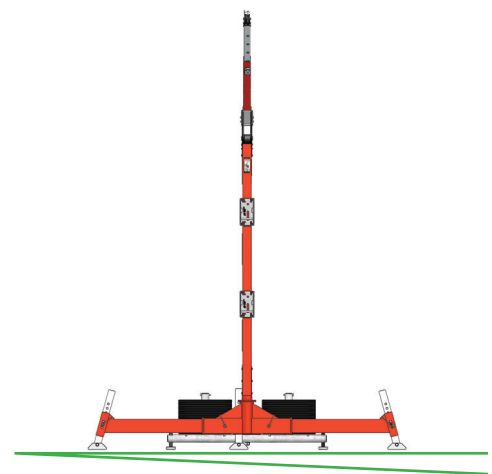

Ground fall Max 5° (170mm / 6.8")