

# SPECIFICATION SHEET

## Vehicle Hitch Mount / Counterweight Davit Base



**Code: 30076-KIT**

**Description:**

The BTS PRO-6 Series Hitch Mount and Counterweight Base Davit system is your ultimate solution for height safety, fall arrest, leading edges and confined space entry and retrieval applications such as manholes, silos and pump stations. The PRO-6 Series Portable Hitch Mount Bases are designed for rugged and demanding applications using external weight sources to anchor the davit system.

**Features:**

- Easy assembly, no tools required.
- Versatile, counterweighted base or attached to a vehicle with 50mm/2" hitch square receiver.
- Adjustable hitch mount height 340mm (13.3") – 710mm (28.0")
- Set up on uneven ground with independently adjustable support legs.
- Base can be rotated from the vehicle hitch up to 90° on either side.
- Full 360° rotation of Pro-6G davit for access and retrieval of workers or goods.
- Storage bag for easy transportation and storage.
- Separates into easy to carry components.
- Rated lifting point on the counterweight frame.

**Standards: when used in a complete system**

- OSHA1926.502 and 1910.140.
- ANSI Z359.18
- AS/NZS 5532 & 1891.4

**Capacity: when used in a complete system**

- Fall Arrest: Up to 2 users 140kg (310lbs) each.
- Work positioning: Up to 2 users 140kg (310lbs) each.
- Rescue retrieval: Up to 2 users 140kg (310lbs) each.
- MRC / WLL / Load: 140kg (310lbs) Max.

**2 USERS = 1 in pit & 1 operating winch**

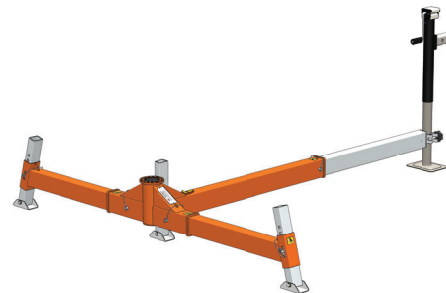
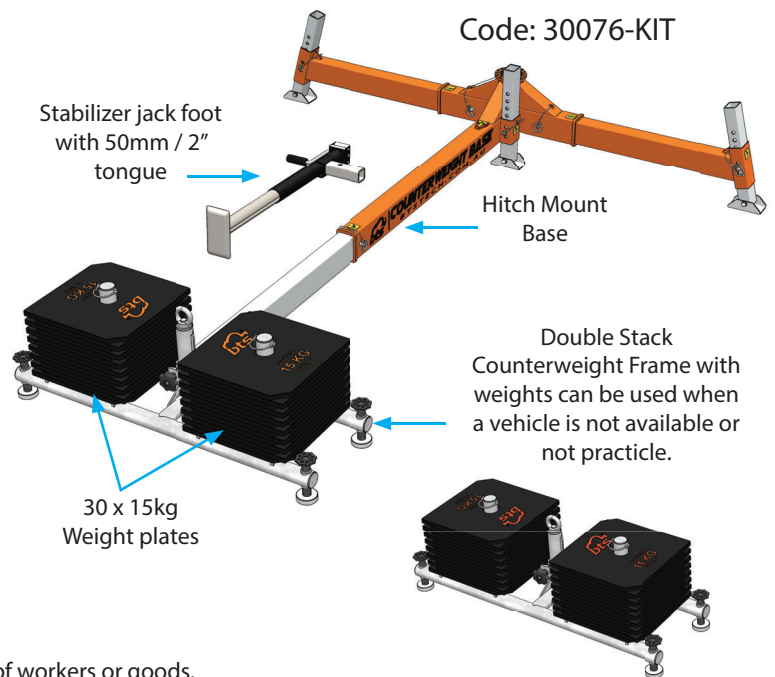

Adjustable hitch mount height 340 to 710mm (13.3 - 28")



Tool-free assembly through the use of Clevis pins c/w lynch pin retainer and lanyard



Adjustable foot height



# SPECIFICATION SHEET

## Vehicle Hitch Mount / Counterweight Davit Base



### Set-up options

#### Hitch Mount

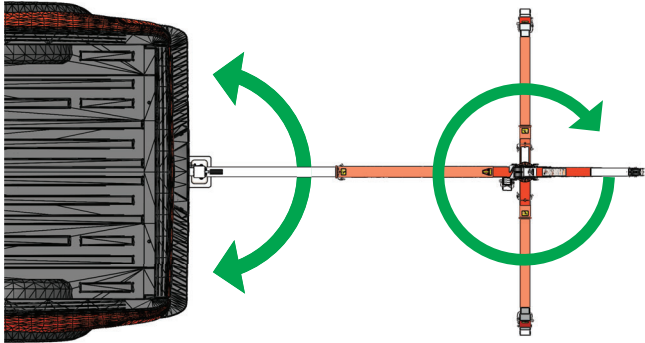

Rotation option of base (up to 90°) and 360° rotation of davit

#### Counterweight

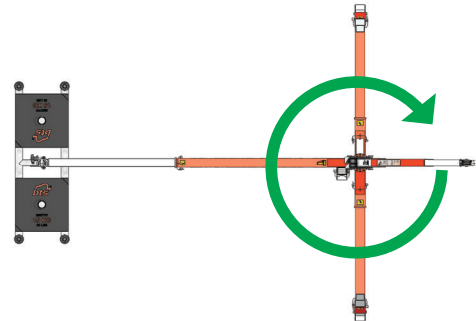

360° rotation of davit

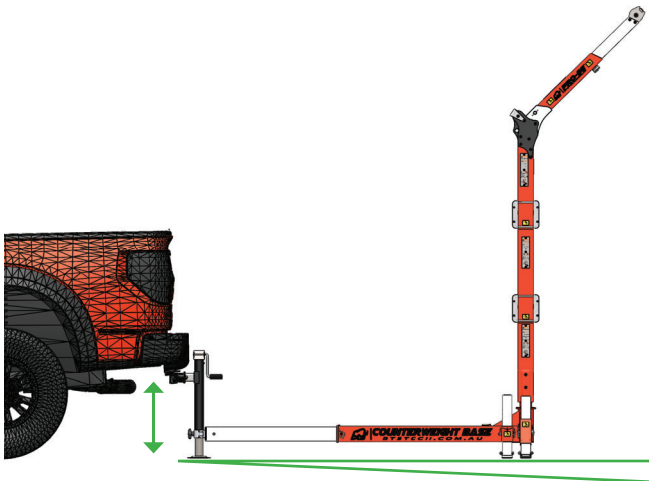

Hitch height options (340-710mm / 13"-28")  
ground fall Max 4° (165mm / 6.5")

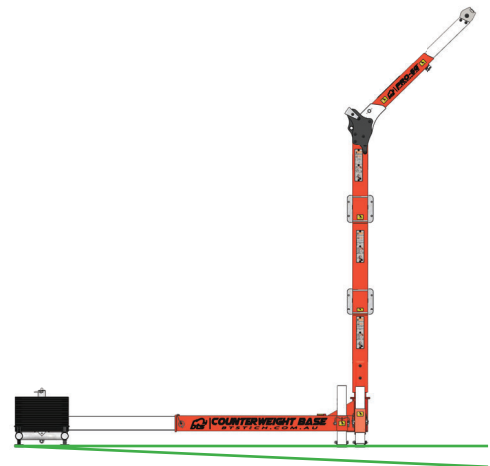

Ground fall Max 4° (165mm / 6.5")

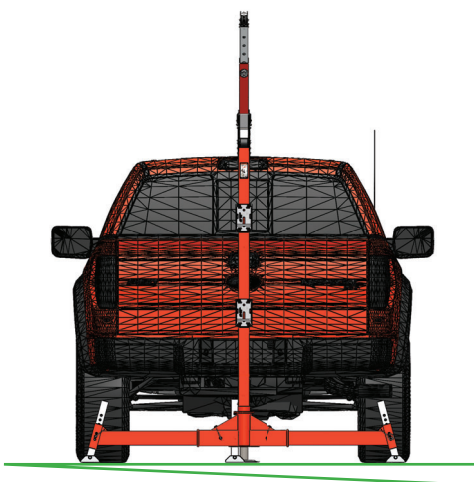

Ground fall Max 5° (170mm / 6.8")

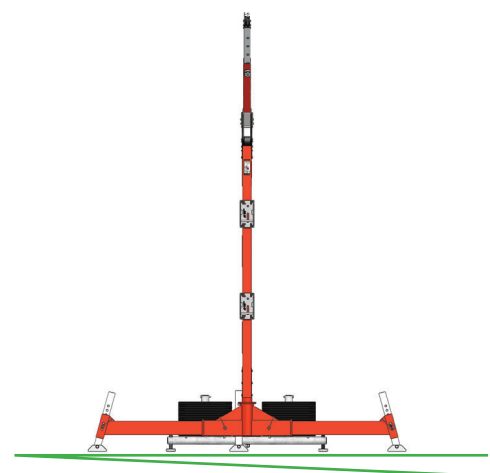

Ground fall Max 5° (170mm / 6.8")

# SPECIFICATION SHEET

## Hitch Mount Vehicle Counterweight Davit Base



**30076S:**

**Hitch mount Vehicle base Counterweight base c/w bag & steel stillage**

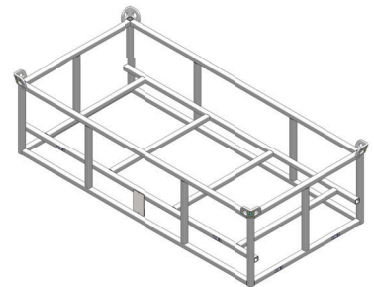
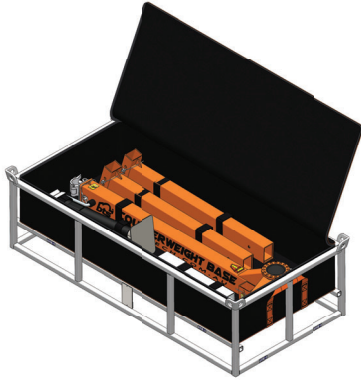

### Davit base Footprint

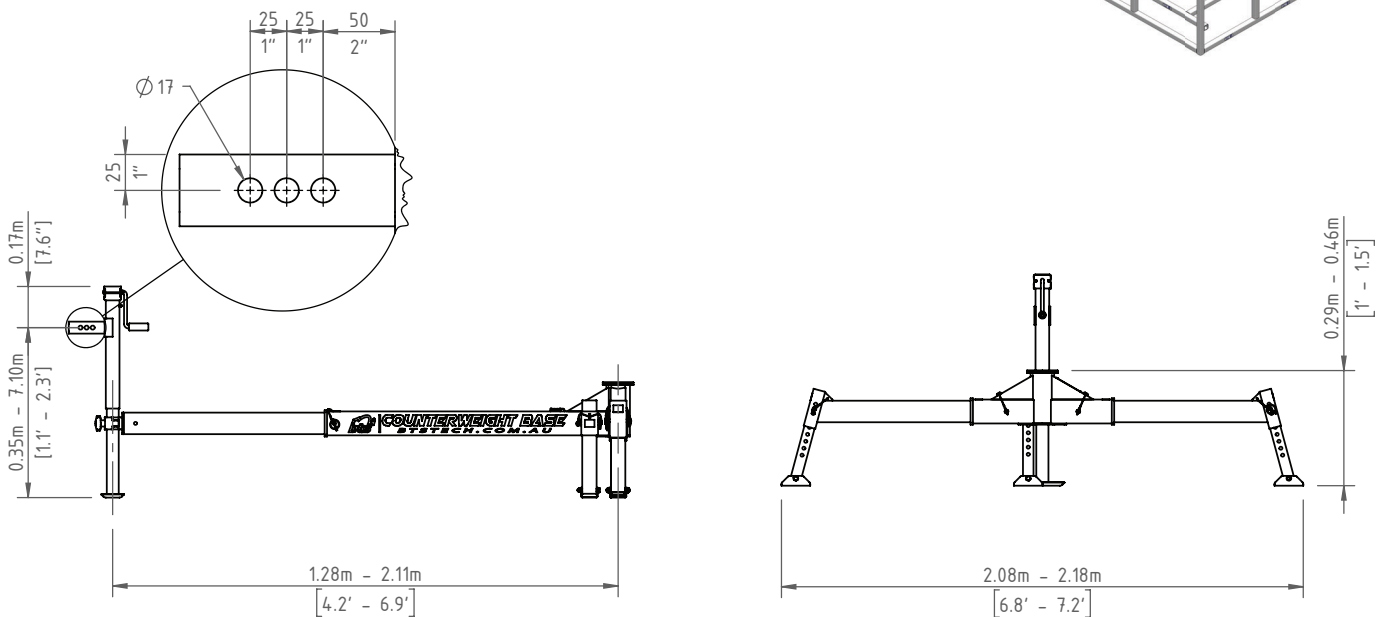

**Weight:** Total 56kg (123lbs)

Separates into easy to carry components: Base weight 12kg (26lbs), Outrigger legs 5kg (11lbs) each, Stabilizer jack 5kg (11lbs), Heavy Duty storage bag 4kg (9lbs). Steel Stillage frame 25kg (55lbs)

### Material specifications:

- Aluminium (Anodized / Powder coated)
- Steel (Galvanized / Painted)

### Shipping dimensions:

**Length:** 1.49m (59") – **Width:** 0.74m (29") – **Height:** 0.43m (17")

**Weight:** 56kg (123lbs)

Also available with stacking stillage for multiple units.



# SPECIFICATION SHEET

## Counterweight Davit Base



**30077K:**

**Counterweight base attachment for 30076S with Weight plates.**



30 x 15 KG / 33 LBS Weight Plates

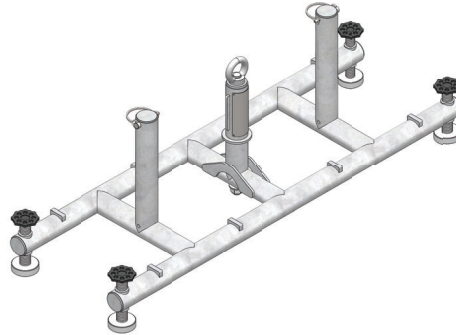

Counterweight Base



Complete unit

### Counterweight base Footprint

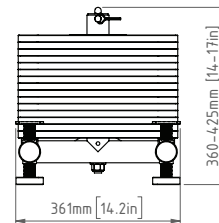
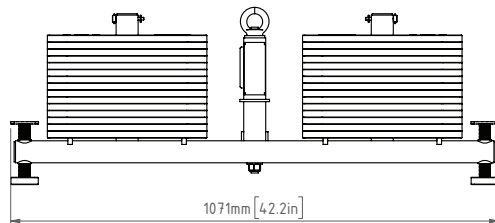
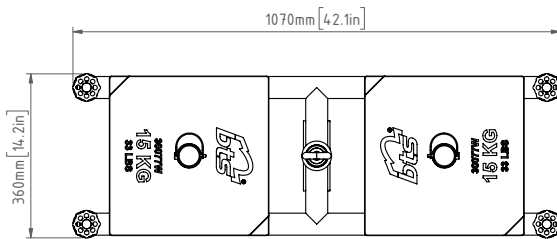

**Weight:** Total 465kg (1025lbs)

- Separates into easy to carry components: Weight plates 30x 15kg (33lbs) with Counterweight frame (18kg).

#### Material specifications:

- Steel (Galvanized / Painted / Electrophoresis coating / Rubberized coating)

#### Shipping dimensions:

**Length:** 1.07m (42") – **Width:** 0.36m (14") – **Height:** 0.42m (17")

**Weight:** 465kg (1025lbs)

*Also available with stacking stillage for multiple units.*

