

# SPECIFICATION SHEET



## Wall mount davit base

CODE: BTS0024

### SPECIFICATION

This equipment is considered as part of a personal fall arrest system (PFAS) with a maximum capacity of 2 users at 136 kg each.

It can also be used (not concurrently) for materials handling with a maximum working capacity dependent to specific davit used.

### MATERIAL AND CONSTRUCTION

Plate, gussets and sleeve: HDG (MS)

Sleeve bearing: PVC Pipe.

### WEIGHT

(est.) 6.2 kg

### RESTRICTIONS

- This davit base is designed to be used in combination with other equipment from the BTS range and/or any other equipment from other manufacturers that the installer has received approval in writing from BTS.
- Anchorage hardware must be installed by qualified and experienced personnel.
- The installer must follow the anchorage hardware manufacturers recommendations at all times.
- Periodic inspections of hardware must be done.
- In the occurrence of a fall or if the safety of the equipment is in doubt, equipment must be removed immediately from service and
- inspected by qualified and/or competent personnel.
- This equipment must always be operated in a level position.



TO SUIT Ø76.2mm (3")  
DAVIT MAST

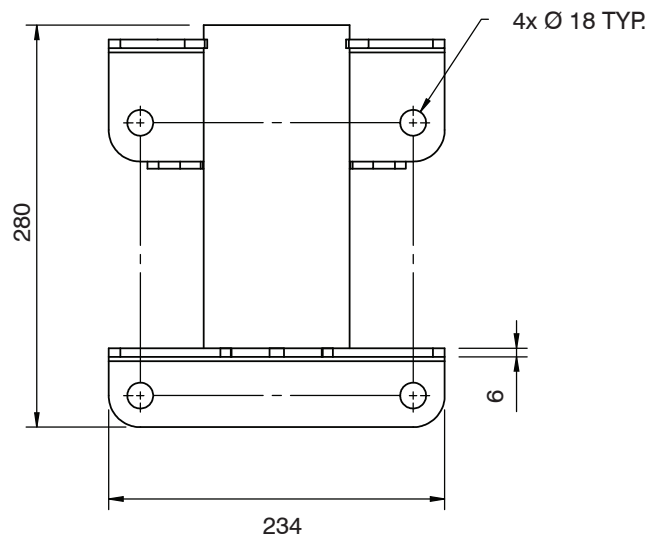
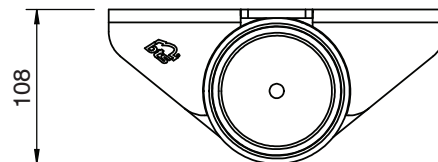
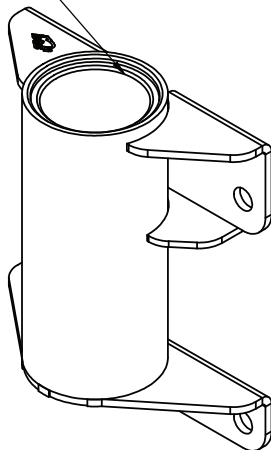

This equipment meets the following standards:  
AS/NZS 5532:2013  
CEN/TS 16415:2013 (2 Users)  
EN 795:2012 (Type B Anchor)

# SPECIFICATION SHEET

## Wall mount davit base



### INSTALLATION

### 4X M16 FASTENER

CODE: BTS0024

#### RECOMMENDATIONS:

Recommendation based on good condition uncracked concrete 32mPa or better.

Slab thickness: 230mm MIN.

Moment capacity: 21,600 N.m

Vertical load: 22.2 kN

Note: It is the responsibility of the installer to assure installation compliance.

Hardware: Hilti HAS-U 8.8 HDG M16x190 or equivalent - Qty. 4

Effective embedment depth: 143mm

Adhesive: Hilti HIT-HY 200-R or equivalent

Note: Minimum pull-out strength of 56kN is required. The installer shall proof load test chemset bolts.

This recommendation is based on the given loads and concrete specifications, It is the responsibility of the field engineer to assure the installation and the capacity of the underlying concrete structure.

Suitable for:

PRO-2G - 50015

PRO-3G - 30106

PRO-4 - 50048

PRO-6G - 50506

